

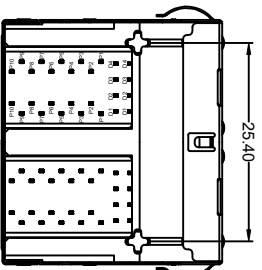

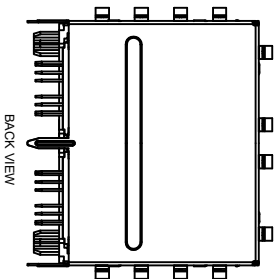

MECHANICAL DIMENSIONS :

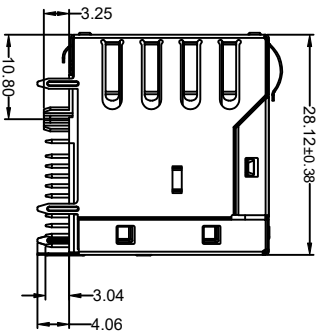
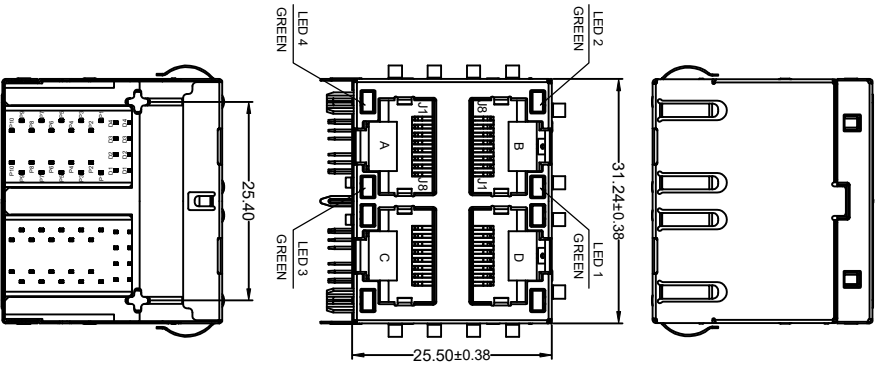

REV:	ECN. NO.	NAME	DATE

For technical support, please send an email to support@vitalconn.com

TOLERANCE UNSPECIFIED		FOR YOUR VITAL CONNECTION	
.0	±0.38		
.00	±0.25		
.000	±0.10		
ANGLE ±2.00°		TITLE:	RJ45 2X2 10/100/1000 BASE-T
MANUFACTURING COPY		PART NO:	J22UG1153DLB6
DRAWN BY:	QSY	UNIT: mm	REV: A
CHECKED BY:	VIT	SIZE: A4	SHEET: 1 OF 5
APPROVED BY:	QPF	PROJECTION	FCN: B6

<http://www.vitalconn.com>

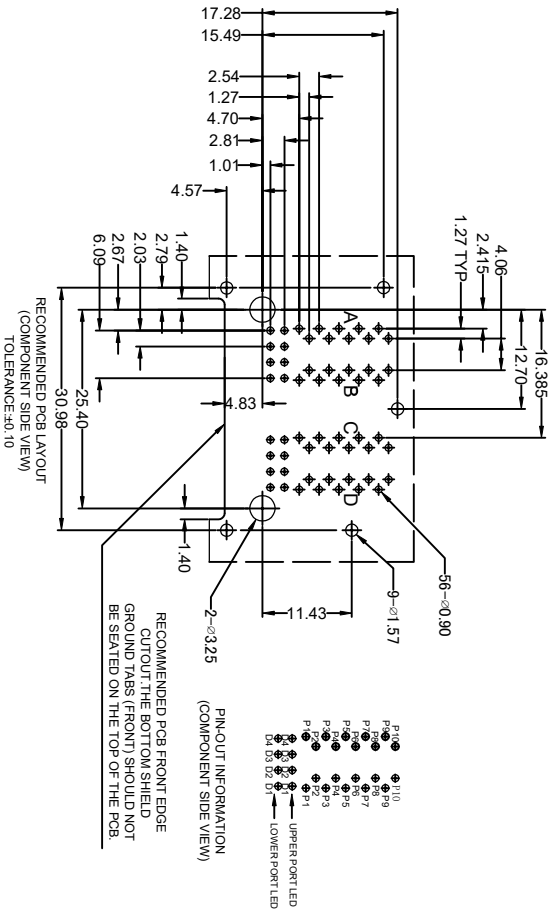

LED 2 & 4 POLARITY		LED 1 & 3 POLARITY	
D4	D3	D2	D1
+	-	+	-
GREEN	GREEN	GREEN	GREEN

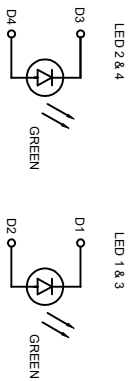

LED ELECTRICAL / OPTICAL CHARACTERISTICS:		
COLOR	IF	V/FORWARD VOLTAGE)
GREEN	20mA	2.2 V
		AD DOMINANT WAVELENGTH
		565nm

For technical support, please send an email to support@vitalconn.com

TOLERANCE UNSPECIFIED	.0	±0.38		FOR YOUR VITAL CONNECTION
	.00	±0.25		
	.000	±0.10		
ANGLE	±2.00°		TITLE:	RJ45 2X2 10/100/1000 BASE-T
MANUFACTURING COPY			PART NO.:	J22UG1153DLB6
DRAWN BY:	QSY		SIZE: A4	REV: A
CHECKED BY:	VIT		UNIT: mm	SHEET: 2 OF 5
APPROVED BY:	QPF		PROJECTION	FCN: B6

REV:	ECN. NO.	NAME	DATE



<http://www.vitalconn.com>

REV:	ECN. NO.	NAME	DATE

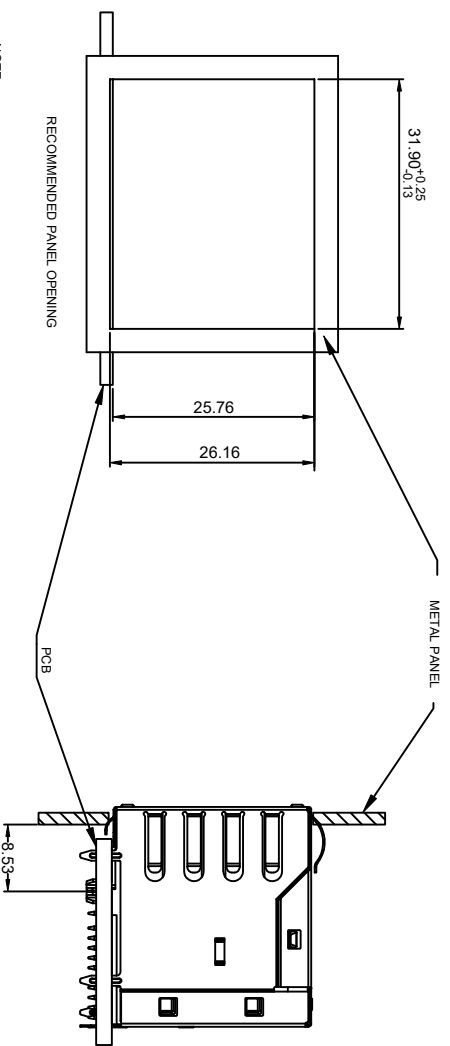
SUGGESTED PANEL OPENING



NOTE:
THE DISTANCE OF PANEL INSIDE SURFACE RELATIVE TO FRONT SURFACE OF PART IS ONLY A SUGGESTION
IN CASE THIS DISTANCE IS DIFFERENT, THE REQUIRED PANEL OPENING DIMENSIONS CHANGE ACCORDINGLY.

TOLERANCE UNSPECIFIED	.0	±0.38	 VITALCOM <i>a vital connector company</i>	FOR YOUR VITAL CONNECTION	
	.00	±0.25		TITLE:	RJ45 2X2 10/100/1000 BASE-T
MANUFACTURING COPY	.000	±0.10	PART NO:	J22UG1153DLB6	REV: A
DRAWN BY:	QSY	ANGLE ±2.00°	SIZE: A4	UNIT: mm	SHEET: 3 OF 5
CHECKED BY:	VIT		PROJECTION		FCN: B6
APPROVED BY:	QPF				http://www.vitalcom.com

For technical support, please send an email to support@vitalcom.com

1 2 3 4 5 6 7 8



REV:	ECN. NO.	NAME	DATE

SPECIFICATIONS:

1. COMPLIES WITH IEEE STANDARDS AND ALL 10/100/1000M ETHERNET SPECIFICATIONS INCLUDING 350UH WITH 8MA DC BIAS
2. INTER GRATED MAG-MODULAR DESIGN PROVIDES HIGHER RELIABILITY AND CONSERVES MINIMIZING PCB SPACE
3. HOUSING : THERMOPLASTIC LCP UL94 V0 RATED
4. R45 CONTACT : PHOSPHOR BRONZE C5210 THICKNESS=0.30MM PLATED NICKEL 30U" MIN. 6U" GOLD PLATED ON CONTENT AREA
5. INPUT TERMINAL : BRASS, THICKNESS=0.30MM FINISH : 120U"MIN TIN OVER 50U" MIN NICKEL
6. METAL SHIELDING : COPPER ALLOY WITH NICKEL PLATED (C2680) THICKNESS=0.20MM NICKEL 30U" MIN
7. DIFFERENT COLOR OF LEADS OPTION AVAILABLE
8. OPERATING TEMPERATURE : -40°C TO +85°C
9. STORAGE TEMPERATURE : -40°C TO +85°C

ELECTRICAL SPECIFICATIONS (25°C±5°C) :

1. TRANSMITTER FILTER & RECEIVER FILTER
 - 1.1 INSERTION LOSS:
 - 1 : 1DB MAXIMUM AT 1MHZ TO 100MHZ;
 - 1.2 RETURN LOSS (L_o and L_o ohms):
 - 16dB MINIMUM AT 1MHZ TO 40MHZ
 - 10+20LOG(F/80)DB MINIMUM AT 40MHZ TO 100MHZ
2. COMMON TO COMMON MODE REJECTION:
 - 30dB MINIMUM AT 1MHZ TO 100MHZ
3. CROSS TALK:
 - 35dB MINIMUM AT 1MHZ TO 40MHZ
 - 33+20LOG(F/50)DB MINIMUM AT 40MHZ TO 100MHZ
4. LX:(100KHz, 100mV, 8mA, DC Bias)
 - PINS: (P1, P2),(P3, P4),(P5, P6),(P7, P8)=350UH MINIMUM
5. HI-POT TEST:
 - PINS:(P1-P2) TO (J1-J2) : 1500V AC 60S OR 2250VDC 60S
 - PINS:(P3-P4) TO (J3-J6) : 1500V AC 60S OR 2250VDC 60S
 - PINS:(P5-P6) TO (J4-J5) : 1500V AC 60S OR 2250VDC 60S
 - PINS:(P7-P8) TO (J7-J8) : 1500V AC 60S OR 2250VDC 60S

SCHEMATIC:

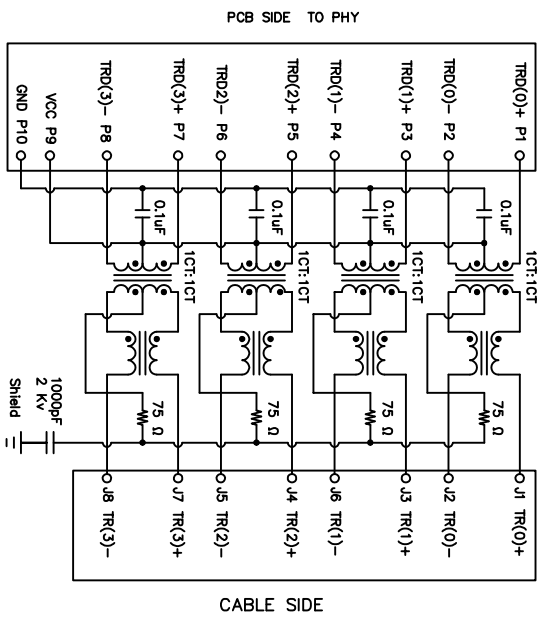

For technical support, please send an email to support@vitalconn.com

TOLERANCE UNSPECIFIED	.0	±0.38	 VITALCONN a vital connector company	FOR YOUR VITAL CONNECTION
	.00	±0.25		
ANGLE	±0.10	±2.00°	TITLE:	RJ45 2X2 10/100/1000 BASE-T
MANUFACTURING COPY			TITLE:	RJ45 2X2 10/100/1000 BASE-T
DRAWN BY:	QSY	PART NO:	J22UG153DLB6	REV: A
CHECKED BY:	VIT	SIZE:	A4	UNIT: mm
APPROVED BY:	QPF	PROJECTION:		SHEET: 4 OF 5
				FCN: B6
				http://www.vitalconn.com

PACKAGE INFORMATION AND LABEL

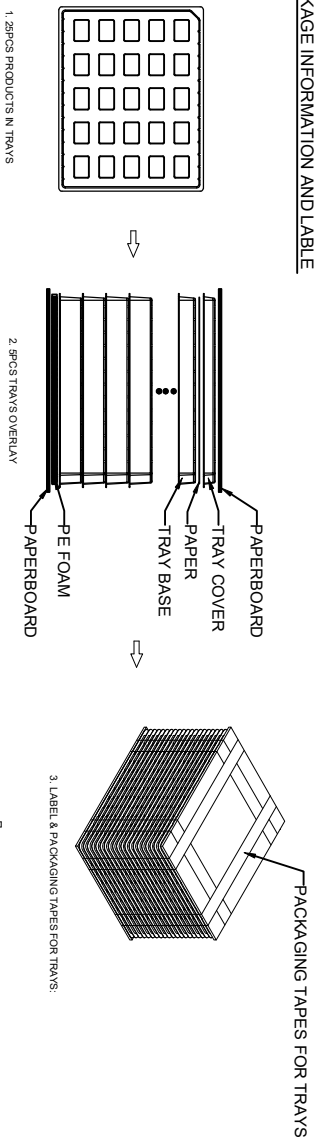

PACKAGING LISTS	
ITEM	QTY
PRODUCT	125 PCS
TRAY COVER	5 PCS
TRAY BASE	5 PCS
PAPER	5 PCS
PE FOAM	1 PCS
BOX(L340*W285*H200MM)	1 PCS
LABEL	1 PCS
PACKAGING TAPES	8 M (ABOUT)

For technical support, please send an email to support@vitalconn.com

TOLERANCE UNSPECIFIED	.0	±0.38	TITLE:	R445 2X2 10/100/1000 BASE-T
	.00	±0.25		
.000	±0.10	ANGLE ±2.00°	PART NO:	J22UG1153DLB6
MANUFACTURING COPY			SIZE: A4	REV: A
DRAWN BY:	QSY	PROJECT	UNIT:mm	SHEET: 50F5
CHECKED BY:	VIT	PROJECTION		FCN: B6
APPROVED BY:	QPF			



FOR YOUR
VITAL CONNECTION