

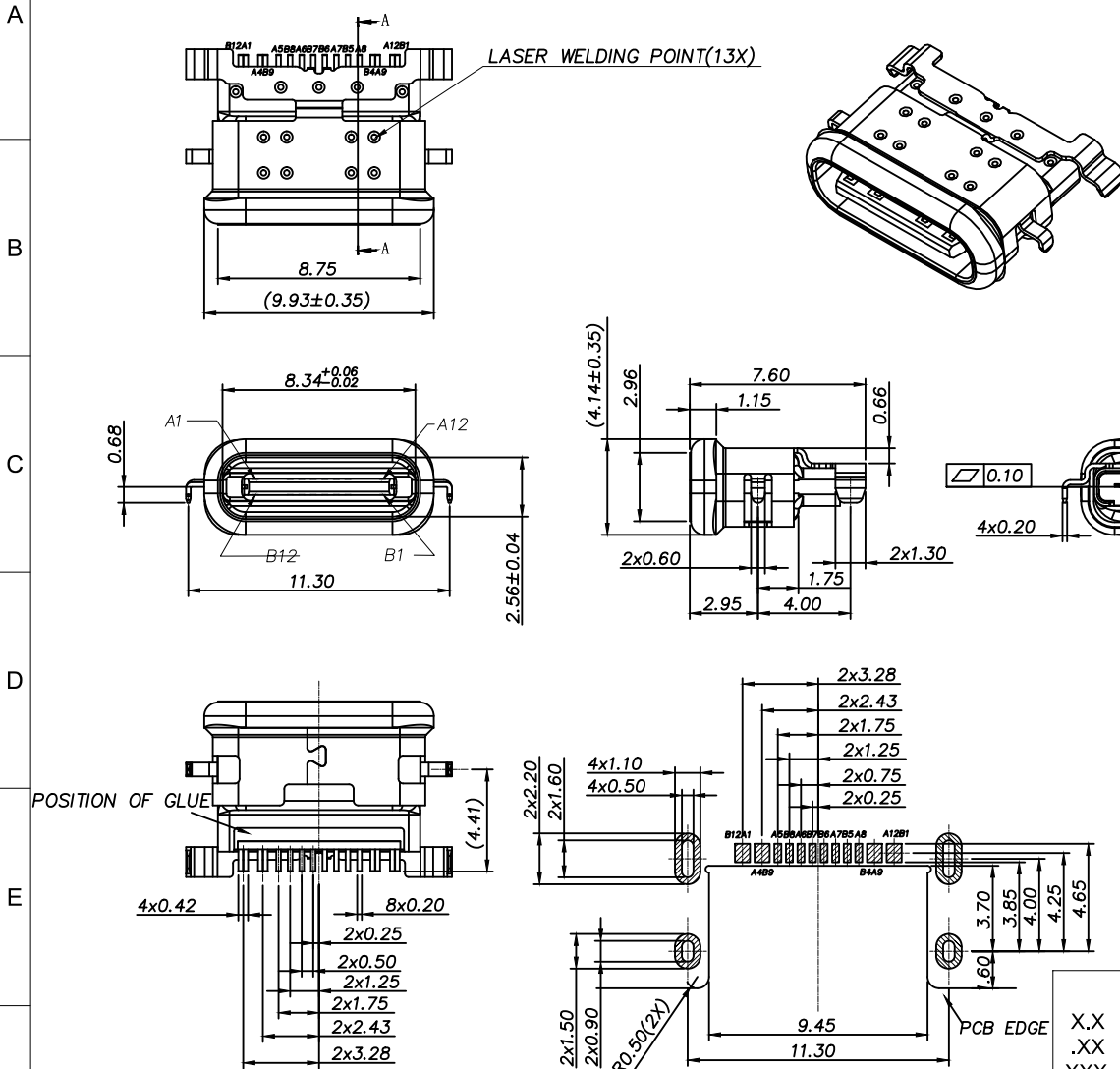

REV:	ECN. NO.	NAME	DATE

- NOTE:
- MATERIAL SPECIFICATION:
 - HOUSING: HIGH TEMPERATURE RESISTANT PLASTIC, UL94 V-0.
 - TERMINAL: COPPER ALLOY
 - MID PLATE: STAINLESS STEEL
 - OUT SHELL: STAINLESS STEEL
 - INNER SHELL: STAINLESS STEEL
 - GLUE: EPOXY, BLACK
 - OUT GASKET: UV GLUE, RED
 - PLATING SPECIFICATION:
 - CONTACTS:
 - Ni 50u" MIN. UNDER PLATED OVER ALL.
 - Au PLATED ON THE FUNCTIONAL AREA OF CONTACT. (GOLD PLATING THICKNESS FOLLOW THE P/N)
 - OUT SHELL & INNER SHELL:
 - Ni 30u" MIN. UNDER PLATED OVER ALL.
 - MID PLATE:
 - CLEAR ONLY
 - MECHANICAL PERFORMANCE,
 - INSERTION FORCE: 0.5~2.0kgf.
 - REMOVAL FORCE: 0.8kgf~2.0kgf.
 - DURABILITY: 10000 CYCLES.
 - ELECTRICAL PERFORMANCE,
 - VOLTAGE RATING: 5 V DC/AC (RMS. max)
CURRENT RATING: 5 AMPS. FOR TOTAL VBUS/GND PINS;
1.25AMPS FOR CC PIN, 0.25 AMPS. FOR ALL OTHER CONTACT.
 - LLCR:
 - VBUS & GND PINS AND OTHER PINS: 40mΩ/PIN MAX.
 - LLCR MAX. CHANGE OF ALL PINS: 10mΩ
 - INSULATION RESISTANCE: 100MΩ MIN
 - DIELECTRIC WITHSTAND VOLTAGE, AC 100V FOR 1 MINUTE.
 - ENVIRONMENTAL PERFORMANCE:
 - OPERATING TEMPERATURE: -25°C~+85°C.
 - IR REFLOW:
 - THE PEAK TEMPERATURE ON THE BOARD SHALL BE MAINTAINED FOR 10 SECONDS AT 260°C.
 - WATERPROOF: IPX7



RECOMMENDED PCB LAYOUT(TOP VIEW)
THICKNESS 1.0±0.10MM; DEFAULT TOLERANCE: ±0.05

TOLERANCE		VITALCON a vital connector company		FOR YOUR VITAL CONNECTION	
X.X ±0.30	X.° ±10°	TITLE: USB CF 16P SMT TYPE MID-MOUNT CH=0		REV: A	
.XX ±0.20	.X° ±8°				
.XXX ±0.10	.XX° ±5°				
UNITS mm		DRAWN BY: Zou Long		PART NO: UC22-1E1H1A103-2HR-24	
APPROVED BY: QPF		CHECKED BY: Bob		SIZE: A4	
PROJECTION		UNIT:mm		SHEET:1 OF 3	
http://www.vitalconn.com		FCN: F9			

For technical support, please send an email to support@vitalconn.com



REV:	ECN. NO.	NAME	DATE

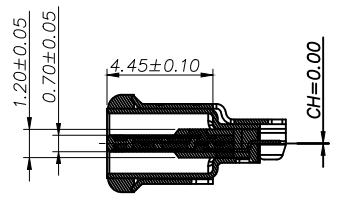

SECTION: A-A

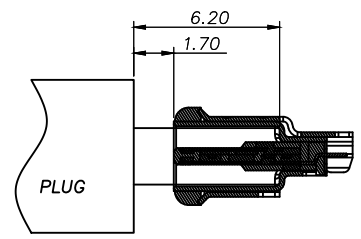

AFTER MATING

RECOMMENDED OPENING DIMENSIONS OF CASE MATING AREA WITH SEALING RING

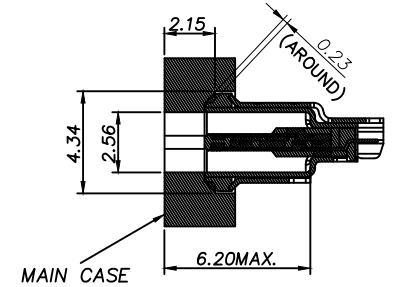
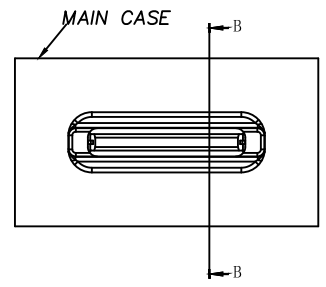

SECTION: B-B

USB TYPE-C PIN ASSIGNMENTS

PIN NUMBER	SIGNAL NAME	PIN NUMBER	SIGNAL NAME
A1	GND	B12	GND
A4	Vbus	B9	Vbus
A5	CC1	B8	SBU2
A6	Dp1	B7	Dn2
A7	Dn1	B6	Dp2
A8	SBU1	B5	CC2
A9	Vbus	B4	Vbus
A12	GND	B1	GND

ORDER INFORMATION

P/N:	UC22-1E1H1A103-2HR-24
HOUSING MATERIAL	E: PA9T
HOUSING COLOR	1: BLACK
SHELL MATERIAL	H: SUS304
SHELL PLATING	1: Ni
	H: HF
	CONTACT FUNCTIONAL AREA PLATED
	03: Au 3u"
	15: Au 15u"
	30: Au 30u"
	CONTACT SOLDER AREA PLATED
	1: Au 1u"
	CONTACT MATERIAL
	A: C1815

TOLERANCE X.X ±0.30 X.° ±10° .XX ±0.20 .X° ±8° .XXX ±0.10 .XX° ±5° UNITS mm				FOR YOUR VITAL CONNECTION	
TITLE:		USB CF 16P SMT TYPE MID-MOUNT CH=0			
DRAWN BY: Zou Long		PART NO: UC22-1E1H1A103-2HR-24		REV: A	
CHECKED BY: Bob		SIZE: A4		UNIT:mm	
APPROVED BY: QPF		PROJECTION		SHEET:2 OF 3 FCN: F9	
				http://www.vitalconn.com	

For technical support, please send an email to support@vitalconn.com



REV:	ECN. NO.	NAME	DATE

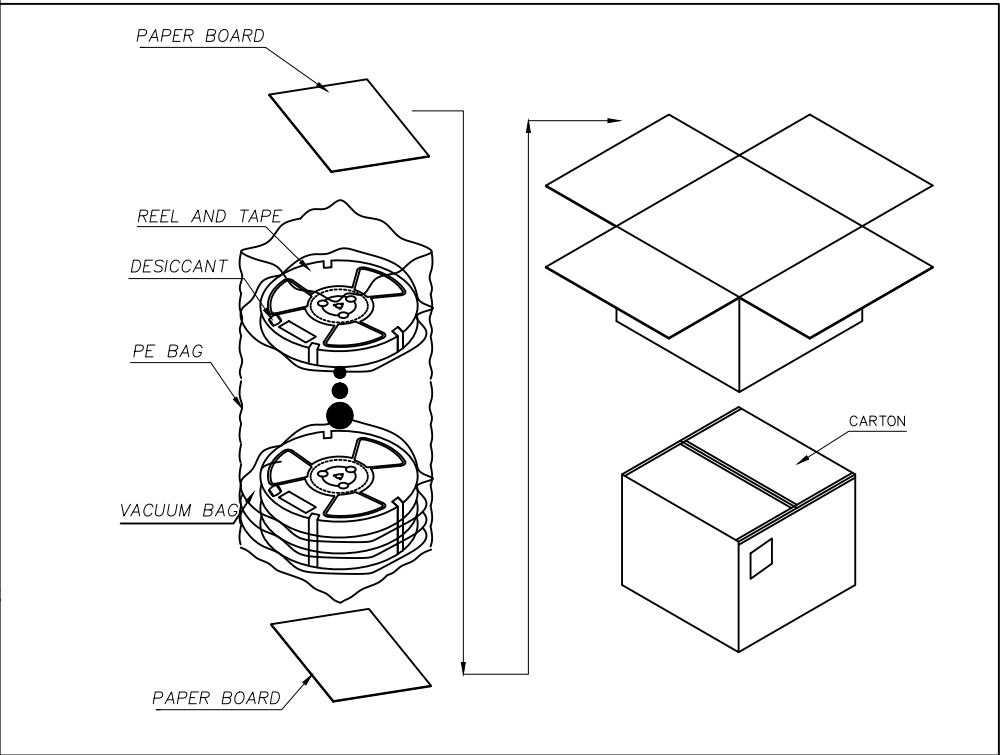
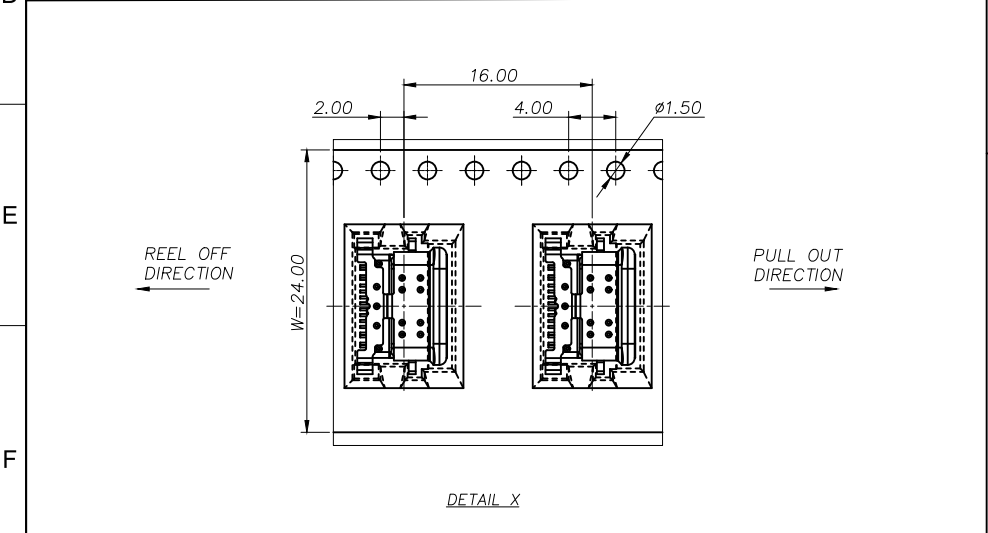
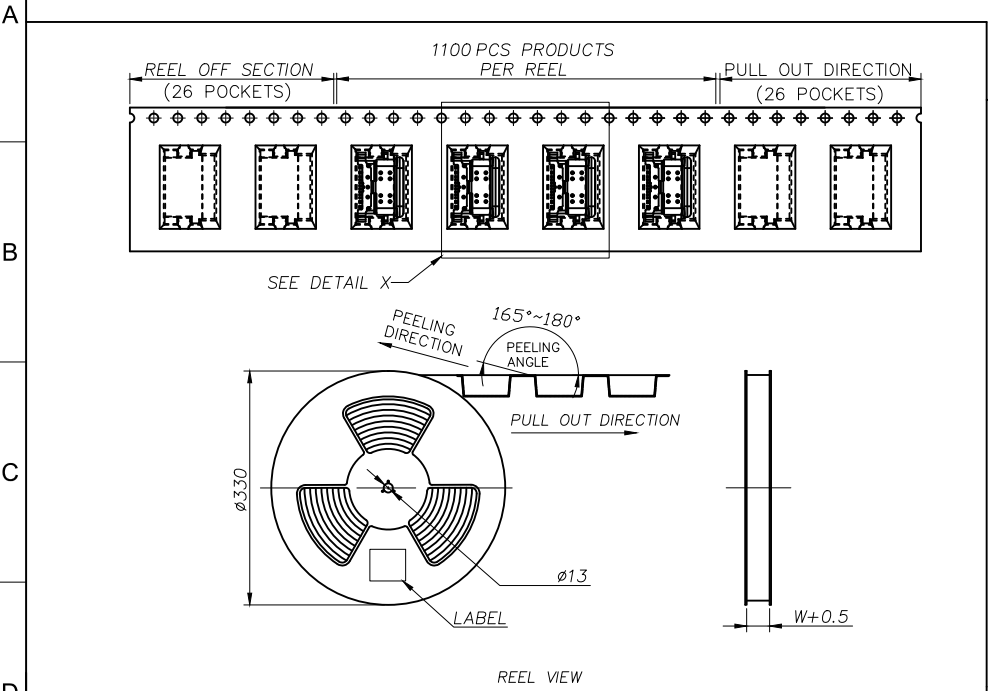

	REEL/TRAY	CARTON
CONNECTOR (PCS)	1100	11000

TOLERANCE X.X ±0.30 X.° ±10° .XX ±0.20 .X° ±8° .XXX ±0.10 .XX° ±5° UNITS mm				FOR YOUR VITAL CONNECTION	
TITLE:		USB CF 16P SMT TYPE MID-MOUNT CH=0			
DRAWN BY:	Zou Long	PART NO:	UC22-1E1H1A103-2HR-24	REV: A	
CHECKED BY:	Bob	SIZE: A4	UNIT: mm	SHEET: 3 OF 3	FCN: F9
APPROVED BY:	QPF	PROJECTION		http://www.vitalconn.com	

For technical support, please send an email to support@vitalconn.com