

REV.	ECN. NO.	NAME	DATE

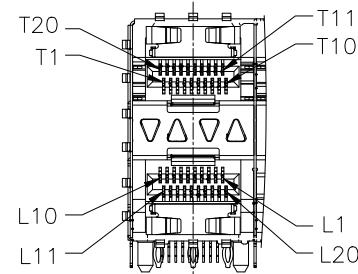

DETAIL A
1:1

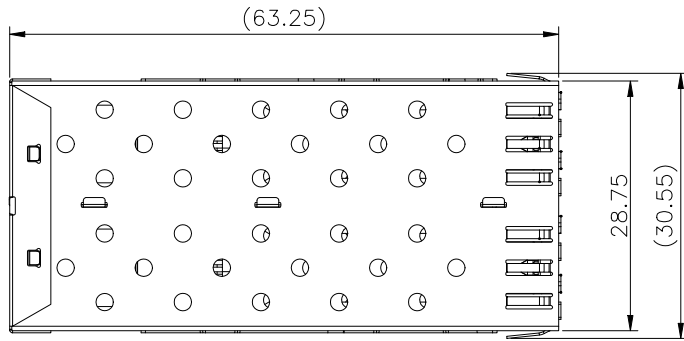
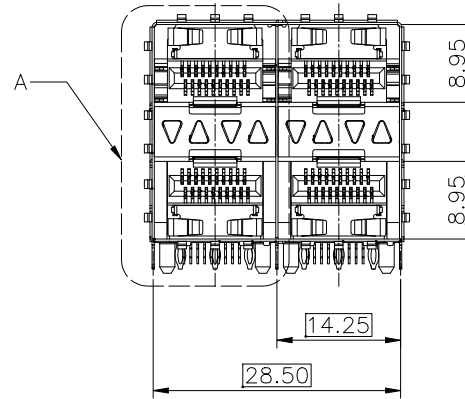
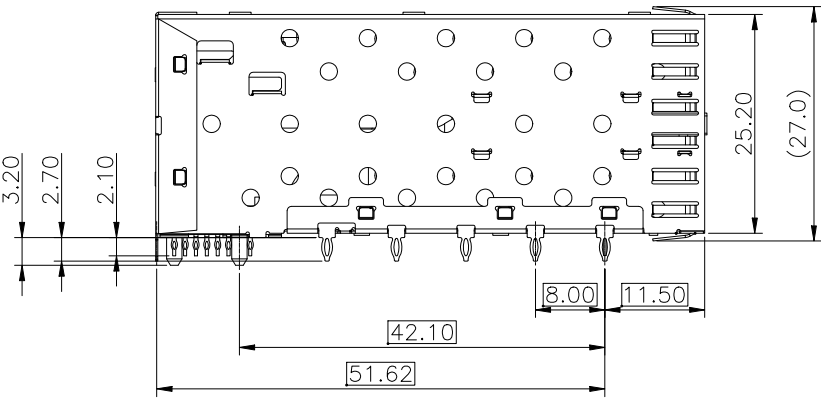

NOTES:

MATERIAL:
 CAGE: NICKEL SILVER, THICKNESS 0.25mm
 LIGHT PIPE: POLYCARBONATE, COLOR: CLEAR.
 CONNECTOR:
 PLASTIC HOUSING: HIGH TEMPERATURE LCP, UL94 V-0.
 SPRING: STAINLESS STEEL, THICKNESS 0.20mm
 CONTACTS: PHOSPHOR BRONZE, THICKNESS 0.20mm
 PLATING: 15μ" MIN. GOLD ON MATING AREA,
 150μ" MIN. MATE TIN ON SOLDER TAILS.

PACKAGING: TRAY PACKAGING.
 TEMPERATURE RANGE: -40°C TO +85°C

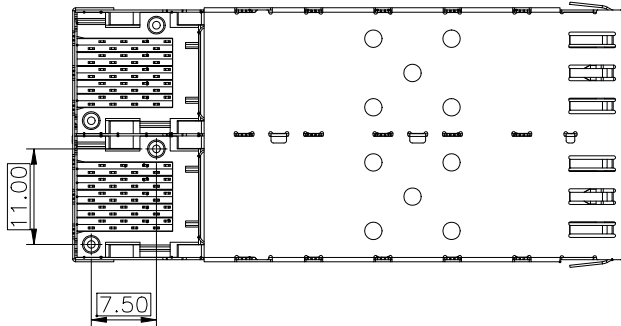

RoHS Compliant

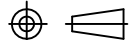
TOLERANCE UNSPECIFIED		 a vital connector company		FOR YOUR VITAL CONNECTION	
.0	± 0.38				
.00	± 0.25	TITLE: SFP2*2 CAGE+CONN			
.000	± 0.10				
ANGLE	± 3.00°				
MANUFACTURING COPY		DRAWN BY: BECKER		PART NO: SC222	
		CHECKED BY: VTA		SIZE: A4	
		APPROVED BY: QPF		UNIT:mm	
		PROJECTION		SHEET:10F3	
				REV: A	
				FCN: A4	
				 http://www.vitalconn.com	

REV.	ECN. NO.	NAME	DATE

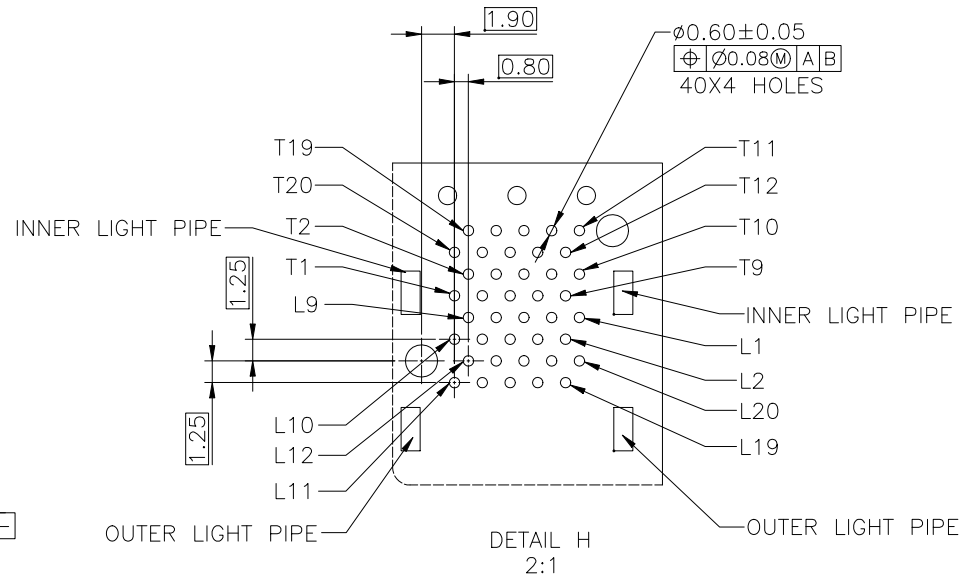
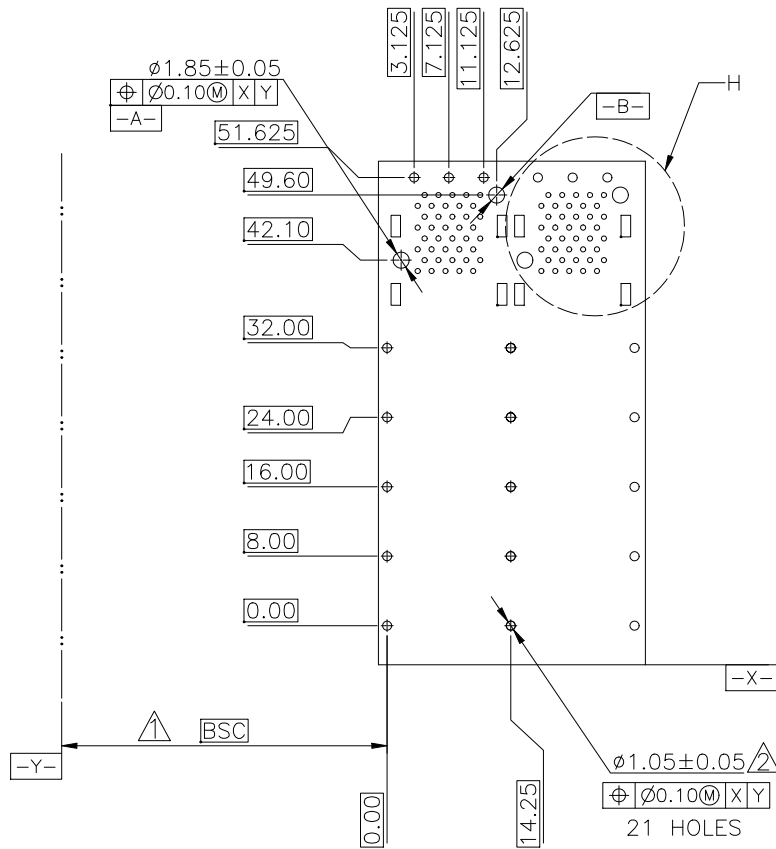

RECOMMENDED PCB CONFIGURATION

NOTES:

- $\triangle 1$. DATUM AND BASIC DIMENSIONS ESTABLISHED BY CUSTOMER.
- $\triangle 2$. 1.05 mm DIAMETER HOLES ARE CHASSIS GROUND (30 HOLES).

RoHS Compliant

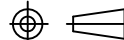
TOLERANCE UNSPECIFIED		 a vital connector company		FOR YOUR VITAL CONNECTION	
.0	± 0.38			TITLE: SFP2*2 CAGE+CONN	
.00	± 0.25	DRAWN BY:	BECKER	PART NO:	SC222
.000	± 0.10	CHECKED BY:	VTA	SIZE: A4	UNIT:mm
ANGLE	$\pm 3.00^\circ$	APPROVED BY:	QPF	PROJECTION	
MANUFACTURING COPY		SHEET:20F3		REV: A	
		FCN: A4		http://www.vitalconn.com	

REV.	ECN. NO.	NAME	DATE

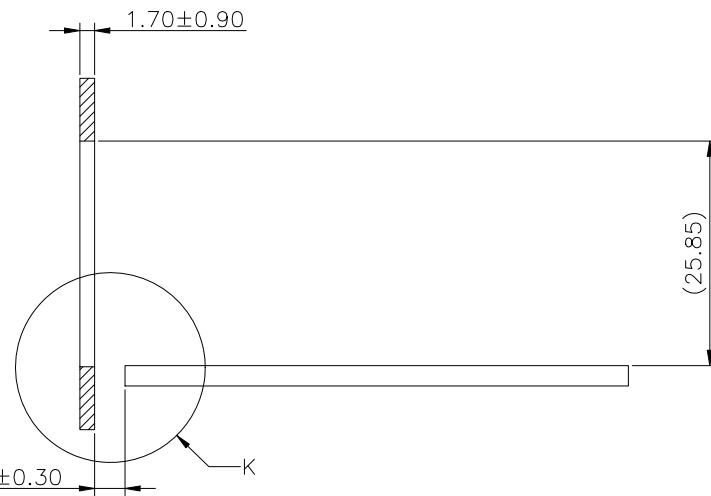
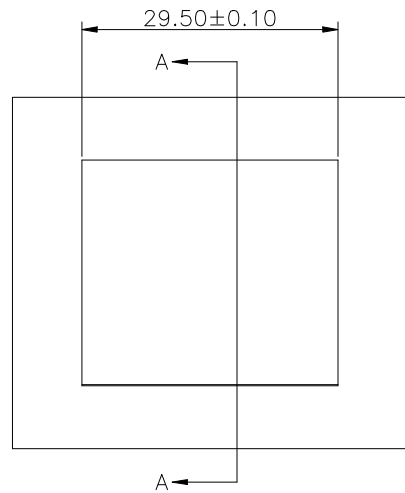

SECTION A-A

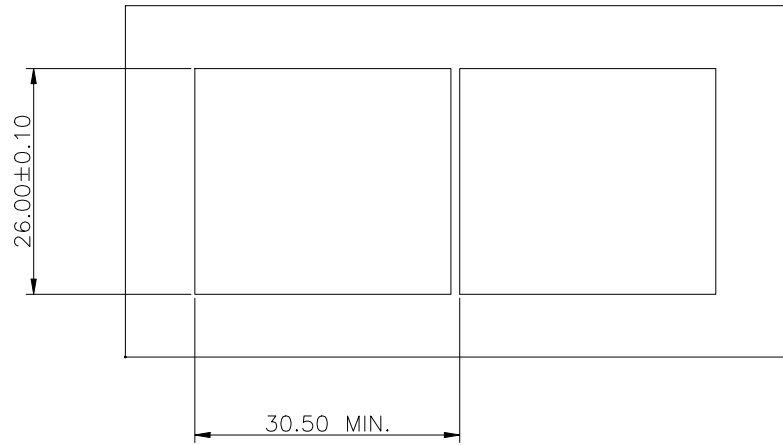

RECOMMENDED BEZEL DESIGN

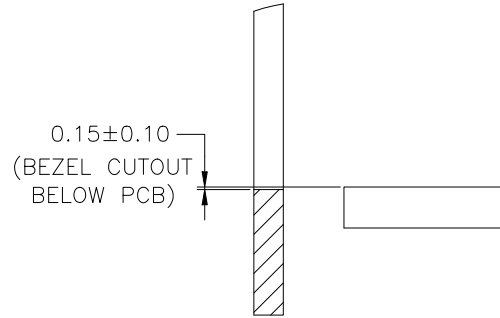

DETAIL K
2:1

RoHS Compliant

TOLERANCE UNSPECIFIED		VITALCON a vital connector company		FOR YOUR VITAL CONNECTION	
.0	± 0.38			TITLE: SFP2*2 CAGE+CONN	
.00	± 0.25	DRAWN BY:	BECKER	PART NO:	SC222
.000	± 0.10	CHECKED BY:	VTA	SIZE: A4	UNIT:mm
ANGLE	± 3.00°	APPROVED BY:	QPF	PROJECTION	
MANUFACTURING COPY		SHEET:30F3		REV: A	
		FCN: A4		http://www.vitalconn.com	